



الكندية للتقوى الكمبربائية المتطورة

CANADA DUCT Ltd.



The leading Manufacturer for air Duct and Accessories in the Middle East

We Deliver air for life.



Fire Rated Rectangular Duct

DESCRIPTION

- Designed for indoor and outdoor installation.

FABRICATION STANDARDS

- Galvanized steel construction.
- Fabricated as per SMACNA standards.
- Thickness : From 14 GI gauge to 16 GI gauge, as per customer's request.
- All the seems are fully welded.
- Angle bar frame flanges.

OPTIONS

- Can be made in Black Steel.
- Stack duct or beaded duct are available.
- Delivered knocked down for site assembly.
- Flame retardant.
- Internal lining.
- External insulation (Double Wall).

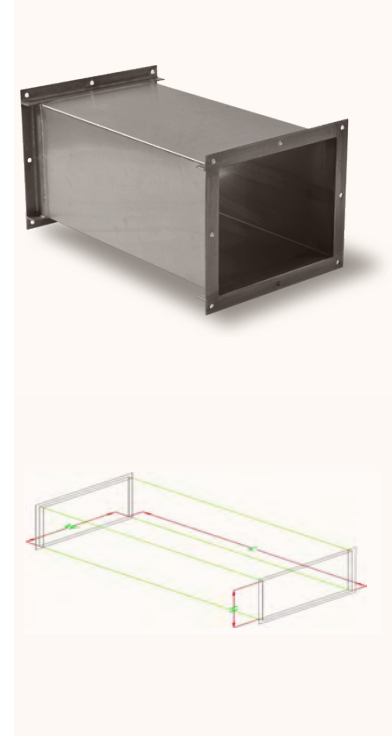

PRODUCT DATA

Rectangular fire rated ducts are available in the following sizes:

Dimension (mm)			Dimension (mm)		
W	H	L	W	H	L
100	100	100	850	850	850
150	150	150	900	900	900
200	200	200	950	950	950
250	250	250	1000	1000	1000
300	300	300	1050	1050	1050
350	350	350	1100	1100	1100
400	400	400	1150	1150	1150
450	450	450	1200	1200	1200
500	500	500	1250	1250	1220
550	550	550	1300	1300	
600	600	600	1350	1350	
650	650	650	1400	1400	
700	700	700	1450	1450	
750	750	750	1500	1500	
800	800	800			

[Continue >](#)

Other Sizes are available upon request

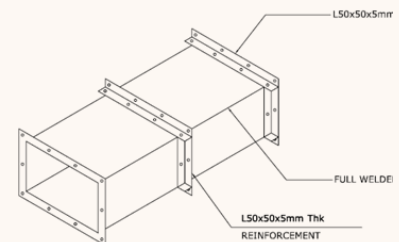

Product Code

EAT GSR-F - WxH / L
WxH= Width x Height
L= Length
Example: GSR-F - 300x300/1000

Fire Rated Single Wall Duct

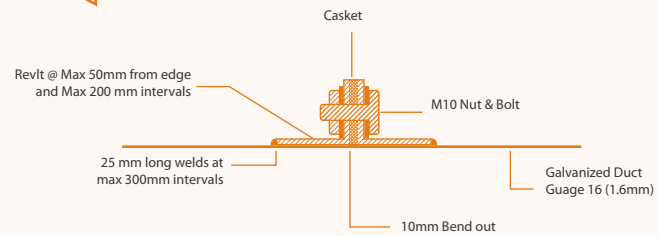
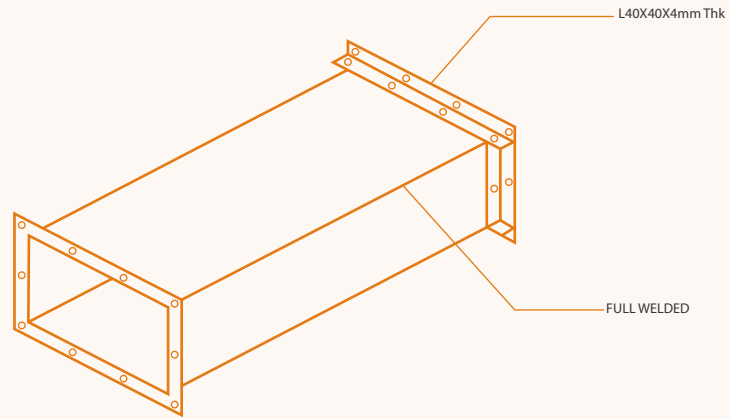

Max Duct Dimension (mm)	US Guage	Longitudinal Seam	Intermediate Reinforcement	Joint Type
0-900	16	Full Welded	-	40X40X4

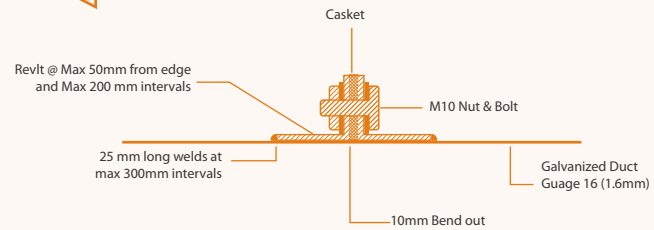
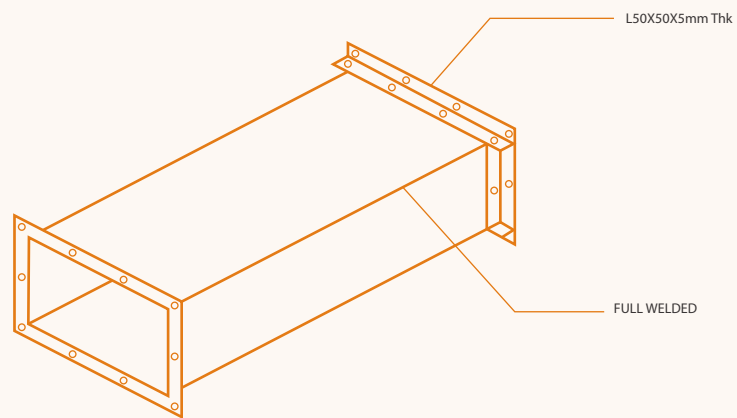

Max Duct Dimension (mm)	US Guage	Longitudinal Seam	Intermediate Reinforcement	Joint Type
901-1200	16	Full Welded	-	50X50X5

Fire Rated Single Wall Duct

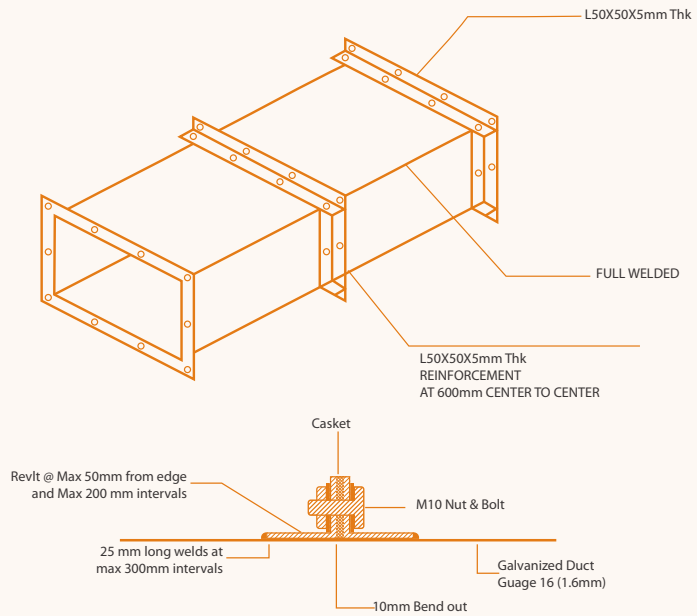

Max Duct Dimension (mm)	US Guage	Longitudinal Seam	Intermediate Reinforcement	Joint Type
1201-1500	16	Full Welded	50X50X5 @ 600 MAX CC	50X50X5

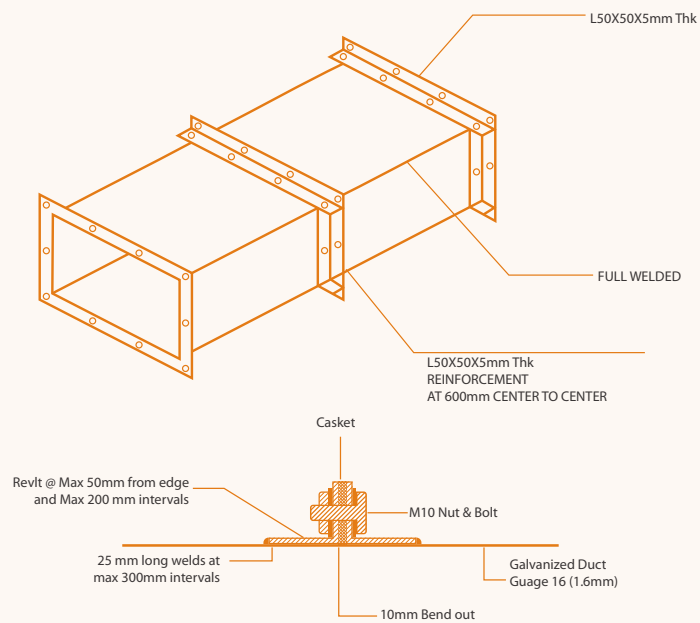

Max Duct Dimension (mm)	US Guage	Longitudinal Seam	Intermediate Reinforcement	Joint Type
1501-1800	16	Full Welded	50x50x5 @ 600 Max CC	50X50X5

Fire Rated Single Wall Duct

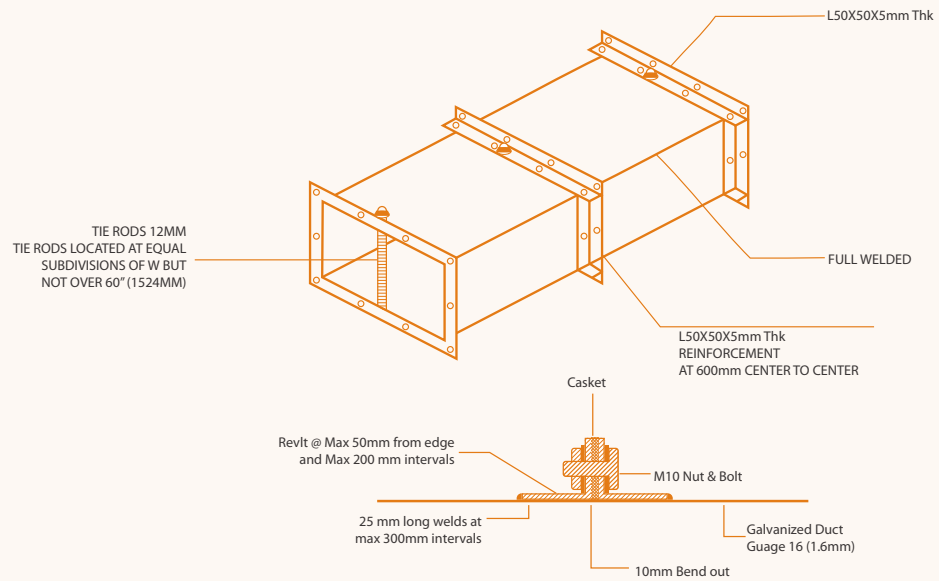

Max Duct Dimension (mm)	US Gauge	Longitudinal Seam	Intermediate Reinforcement	Joint Type
1801-2700	16	Full Welded	50x50x5 @ 600 Maz CC +1 Tie Rod	50X50X5 +1 Tie Rod

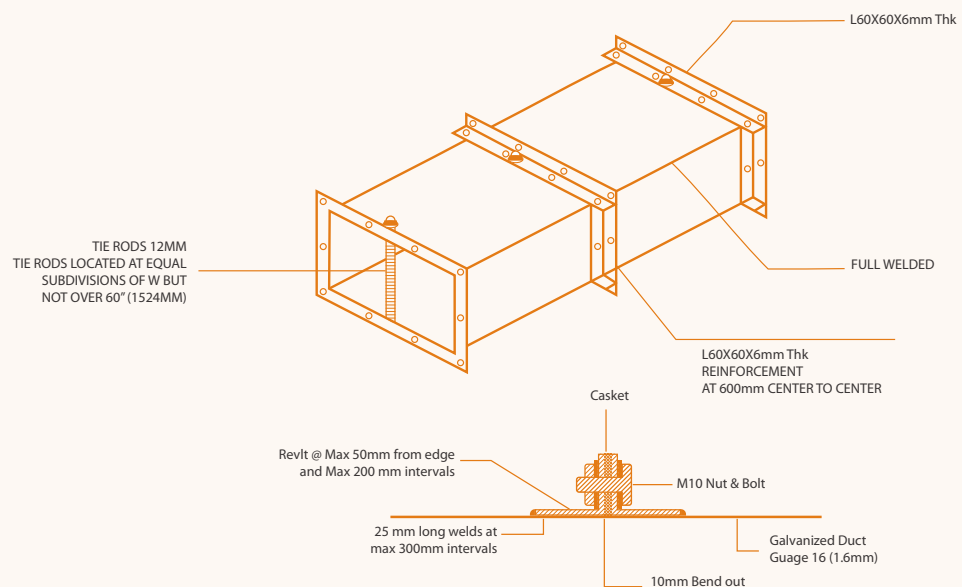

Max Duct Dimension (mm)	US Gauge	Longitudinal Seam	Intermediate Reinforcement	Joint Type
2701-3000	16	Full Welded	60x60x6 @ 600 Maz CC +1 Tie Rod	60X60X6 +1 Tie Rod

Fire Rated Single Wall Duct

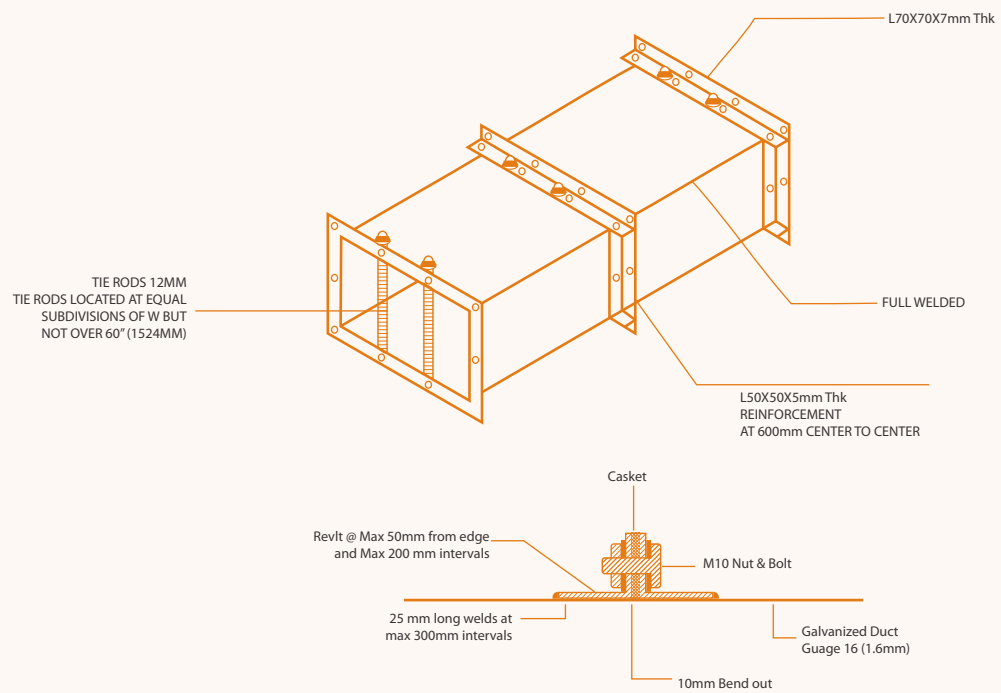

Max Duct Dimension (mm)	US Guage	Longitudinal Seam	Intermediate Reinforcement	Joint Type
3001-4000	16	Full Welded	70x70x7 @ 600 Maz CC +2 Tie Rod	70X70X7 +2 Tie Rod